

SIKORSKI H-34

SPECIAL SERVICE



MKM144173L
1/144 scale

plastic parts 20

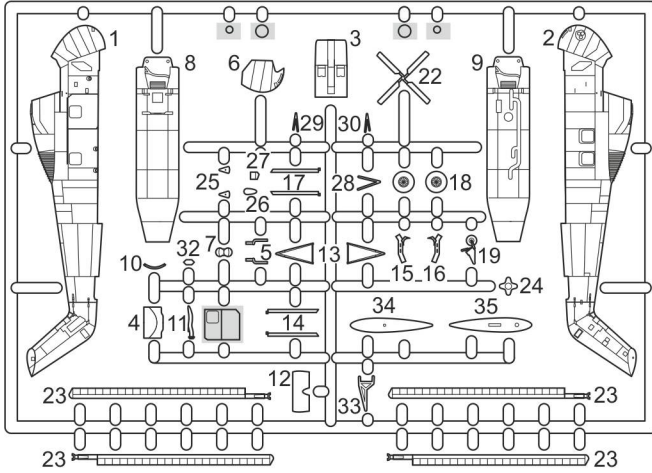

MARK I Ltd.
PO Box 10
CZ-100 31 Prague 10 - Strašnice
Czech Republic
mark1@cmail.cz
www.4pluspublications.com

clear parts

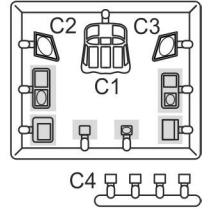

parts not to be used

- Repeat this operation
- Glue
- Don't glue
- Decal
- Detach/cut
- Optional

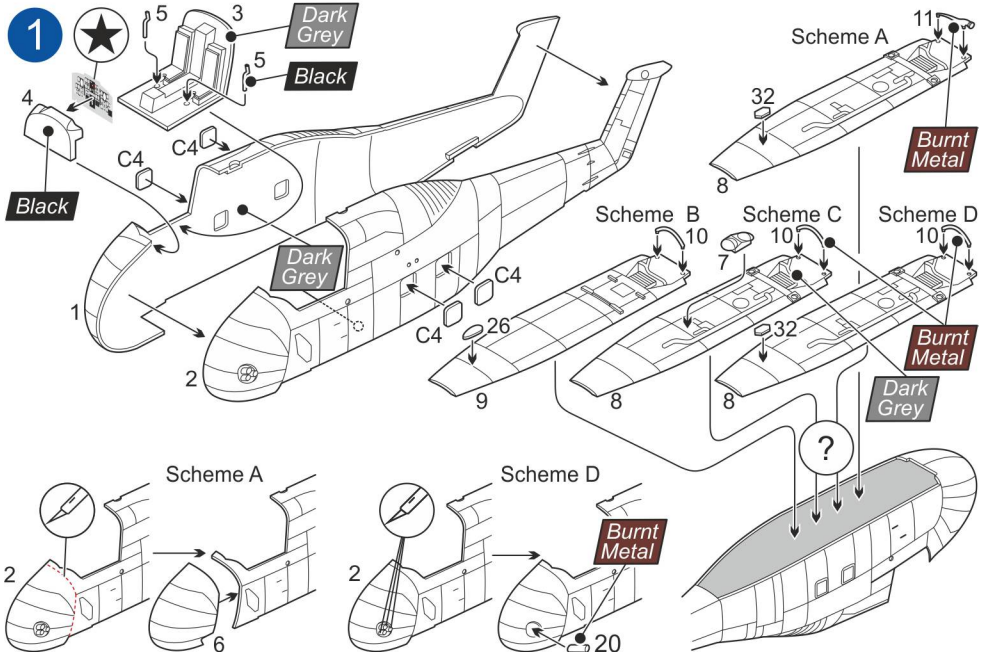

2

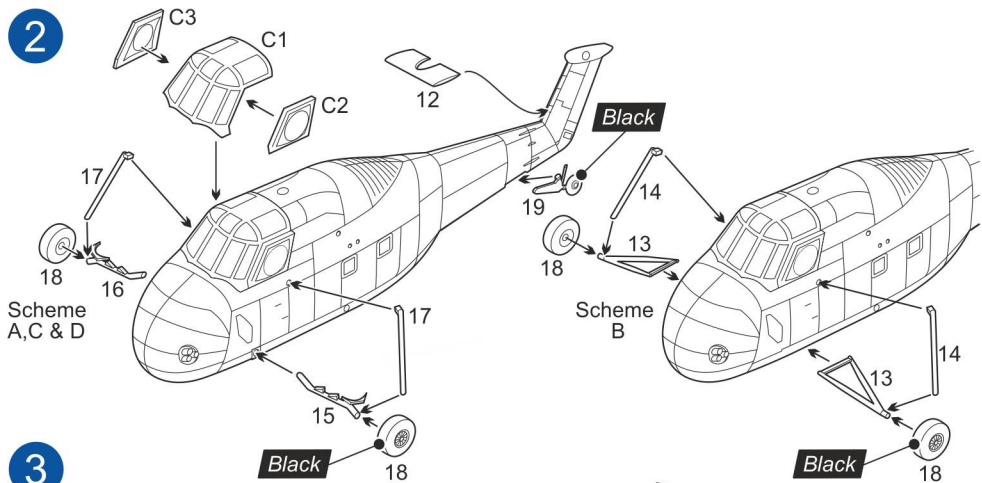

3

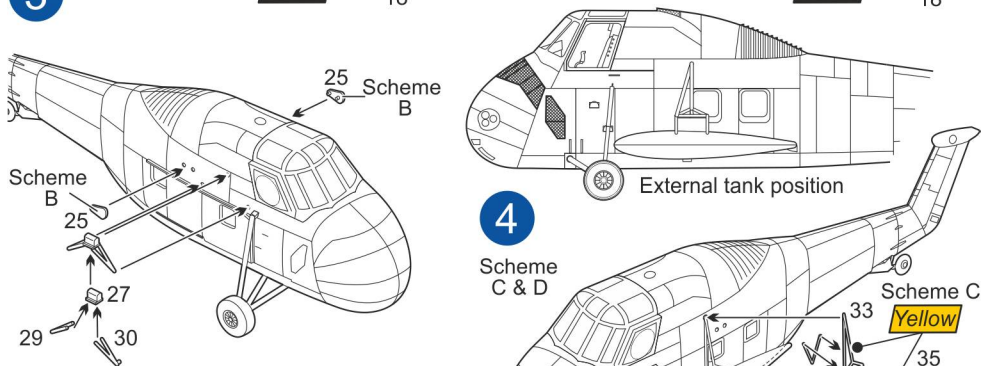

4

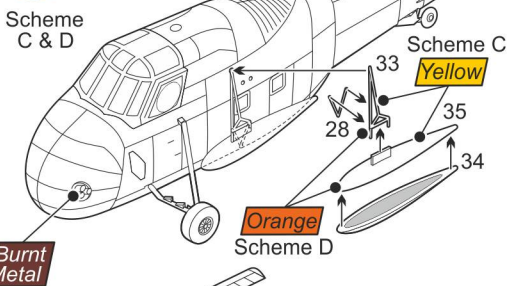

5

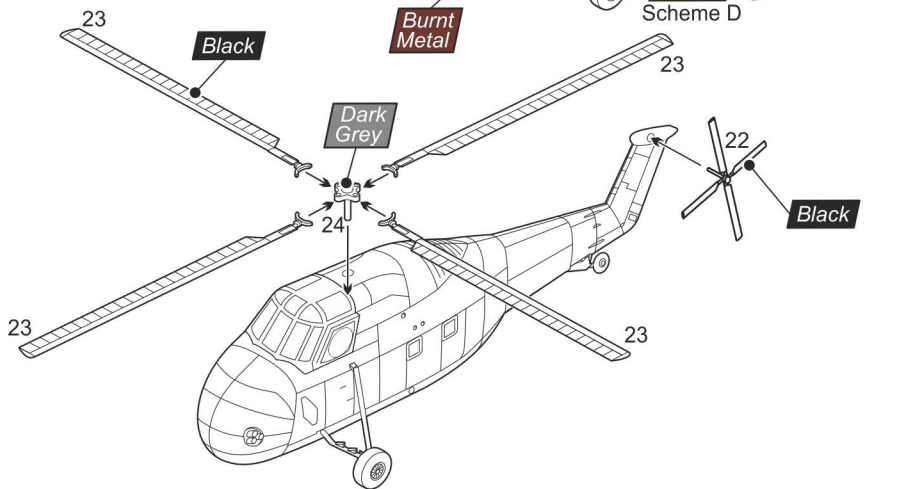

A Sikorsky HSS-1 (SH-34/UH-34G) Seabat, BuNo 141602 (c/n 58-265, G-17-1), Black G17-1, Westland Aircraft trials a/c, RNAY Fleetlands, Hampshire, and Yeovil airfield, Somerset, U.K., June 1956

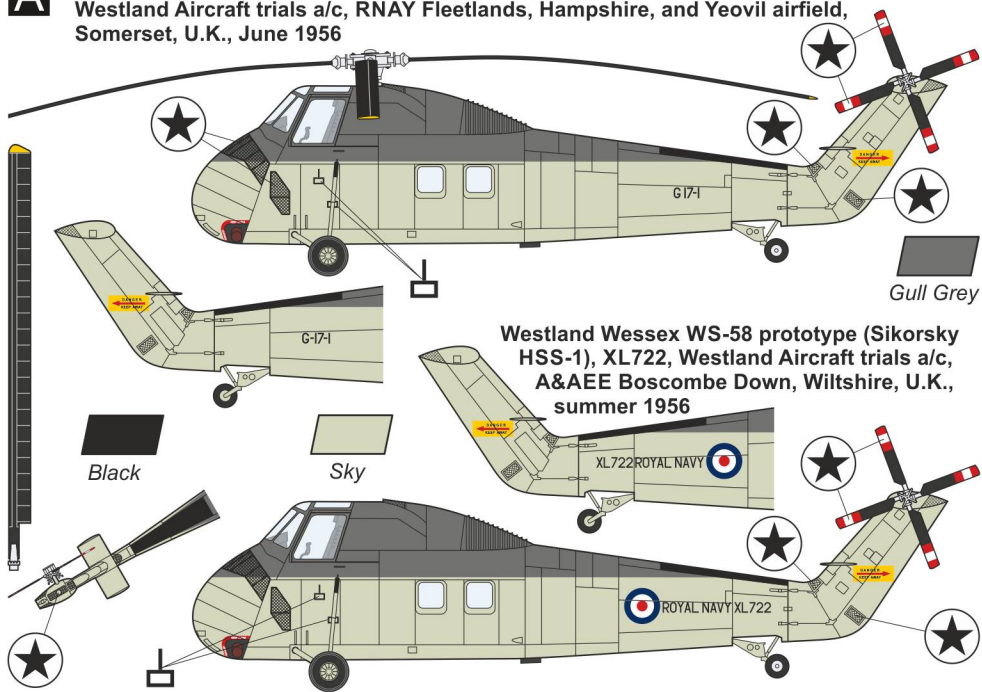

Westland Wessex WS-58 prototype (Sikorsky HSS-1), XL722, Westland Aircraft trials a/c, A&AEE Boscombe Down, Wiltshire, U.K., summer 1956

B Sikorsky HUS-1 (UH-34D) Seahorse, BuNo 148767 (c/n 58-1318), White ET-44, HMR(L)-262 (Marine Helicopter Squadron (Light), 1st Marine Air Wing (MAW), U.S. Marine Corps, Marine Corps Air Station (MCAS) New River, North Carolina, U.S.A., during Mercury-Redstone 3 capsule recovery, North Atlantic Ocean, 5 May 1961

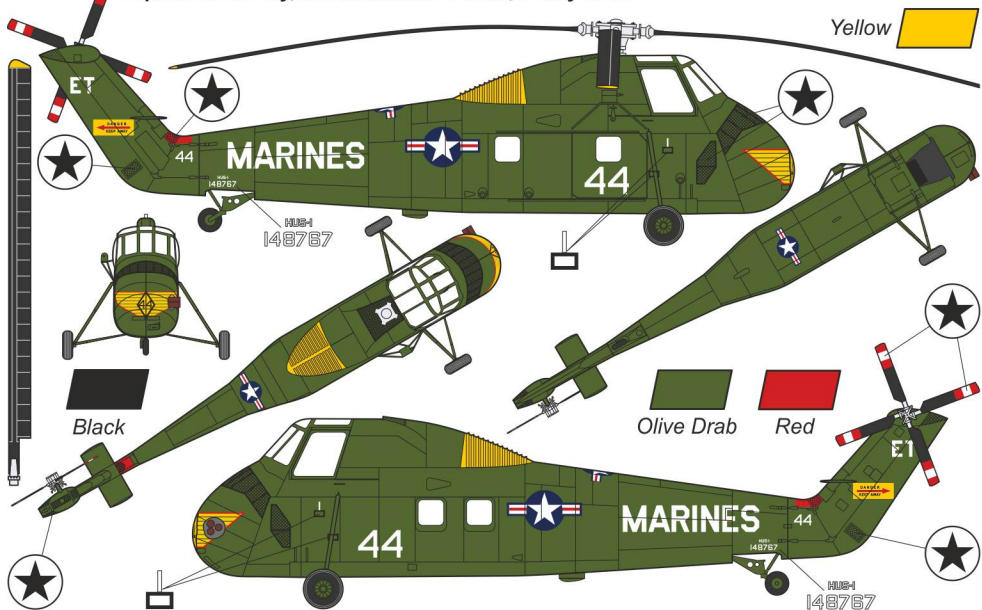

C Sikorsky HUS-1G (HH-34F) Seahorse, 1336 (c/n 58-1063), Air Station St. Petersburg, U.S. Coast Guard (USCG), Coast Guard Air Station (CGAS) St. Petersburg, Albert Whitted Airport, Florida, U.S.A., crashed during a mission in the Gulf of Mexico, 29 November 1962

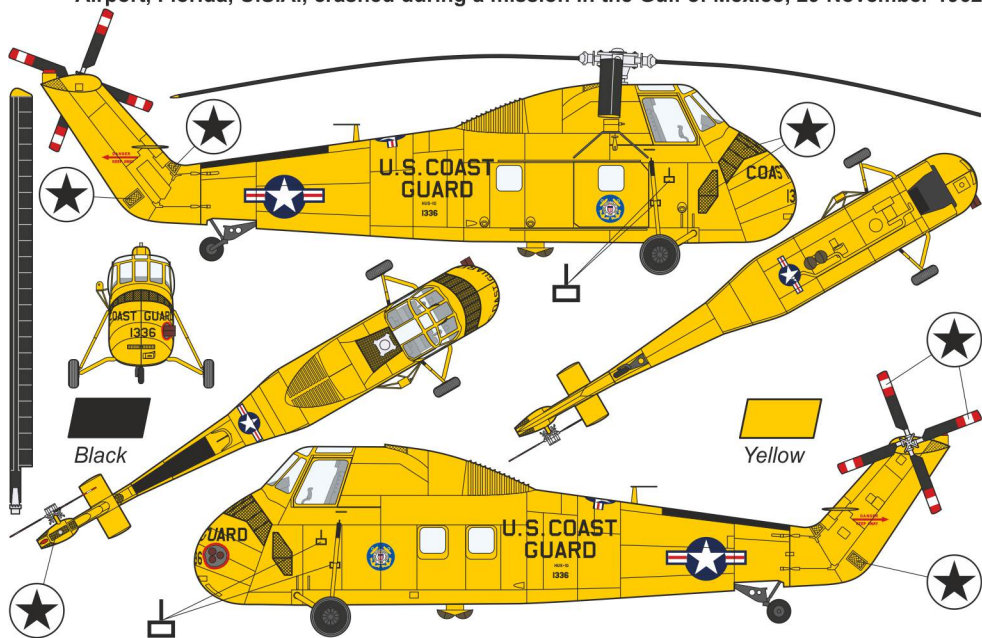

D Sikorsky HUS-1A (UH-34E) Seabat, BuNo 144655 (c/n 58-510), Black JD-26/4655, VX-6 (Air Development Squadron), U.S. Navy, Naval Air Station (NAS) Quonset Point, Rhode Island, U.S.A., during 'Operation Deep Freeze III', Little America Station (LAS), Antarctica, 1957-58

