

CURTISS H-75/MOHAWK MK.IV

EUROPE AND OVERSEAS



MKM144180
1/144 scale

parts not
to be used

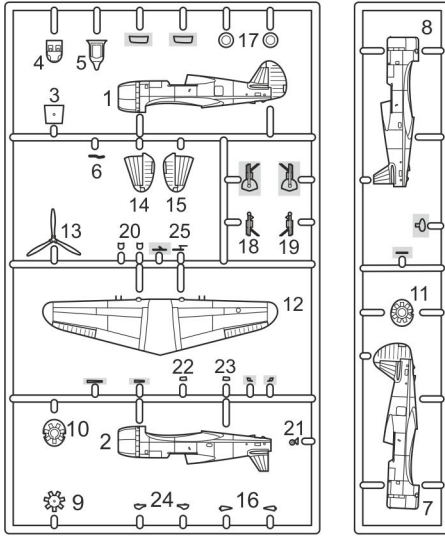

MARK I Ltd.
PO Box 10
Prague 10 - Strašnice
CZ-100 31
Czech Republic
mark1@cmail.cz
www.4pluspublications.com

clear parts

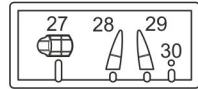

2x

2x

2x

plastic parts

2x Repeat this operation

Glue

Don't glue

Decal

Detach/cut

? Optional

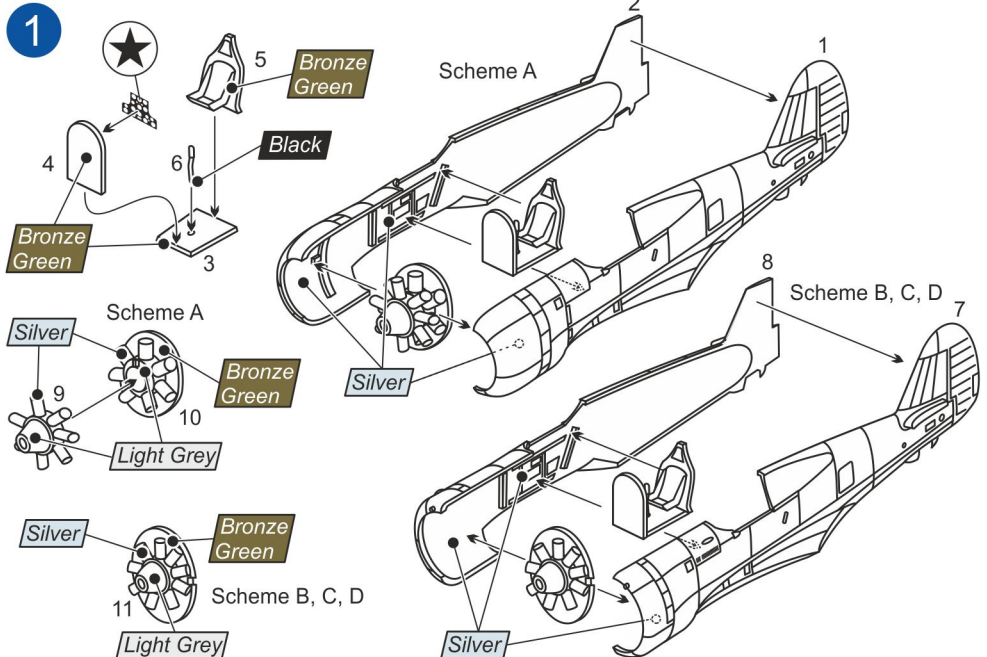

2

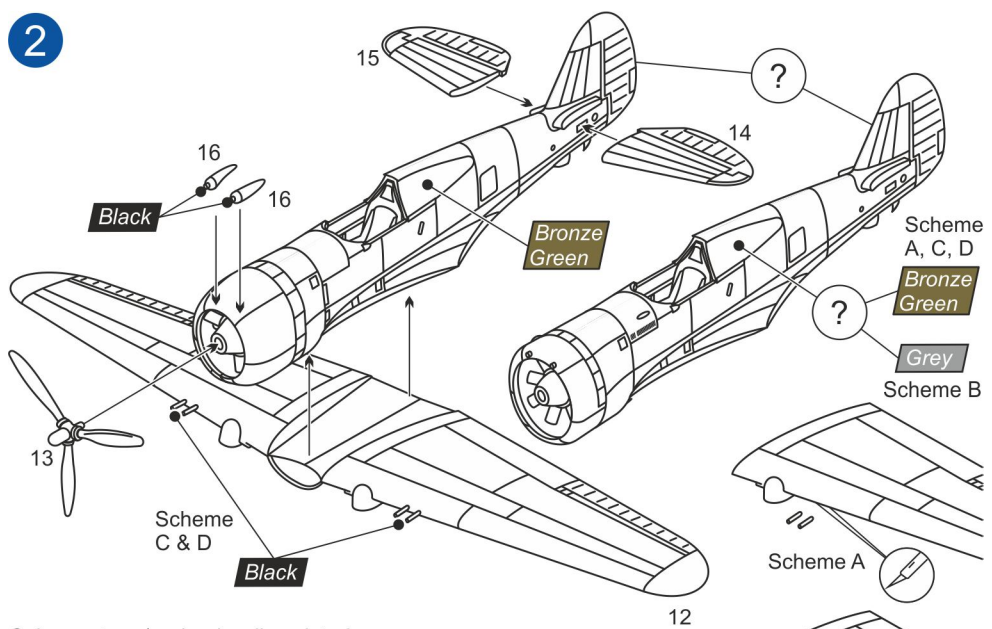

Colour note: u/c wheel wells painted in Bronze Green

3

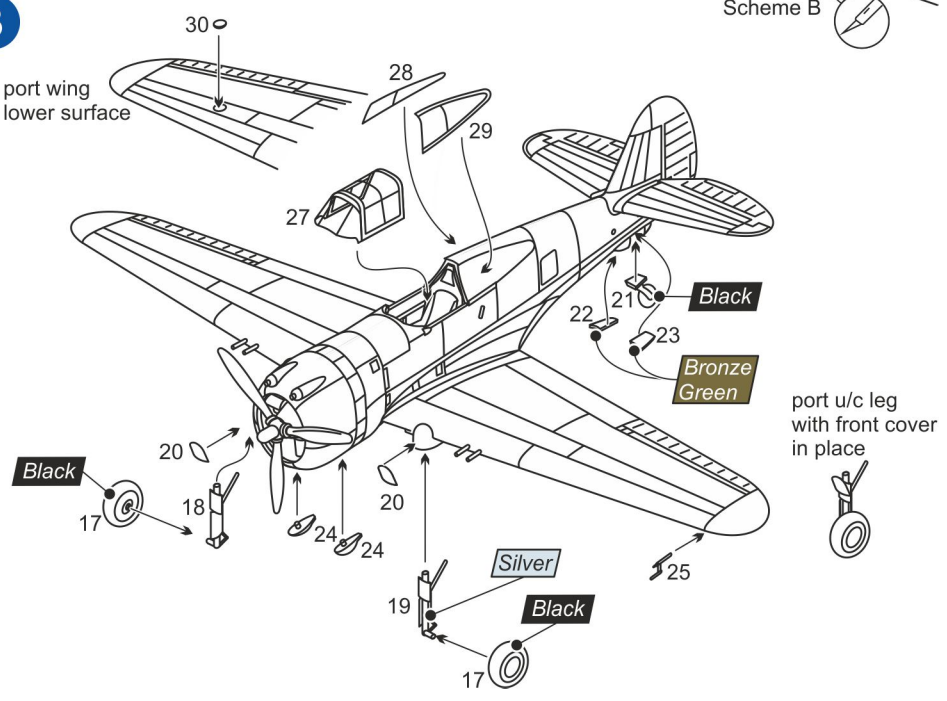

A Curtiss H-751 (H-75A-4), No.51, White 1, École de l'Air (Flying School), French Air Force (Armée de l'Air), Cazaux airfield (BA 706), France, 1946-49

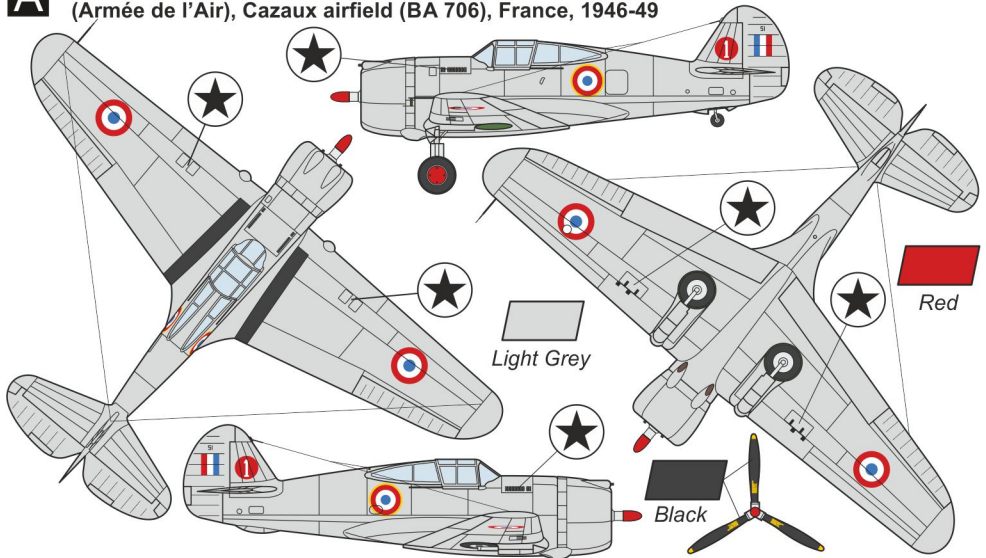

B Curtiss H-75A-7, s/n C-328, Black C328, 1-VLG-IV (1st Sq., 4th Aircraft Group), Royal Netherlands East Indies Army Air Force (Militaire Luchtvaart – Koninklijk Nederlandsch-Indisch Leger, ML-KNIL), Andir airfield, Java, Netherlands East Indies, May 1940

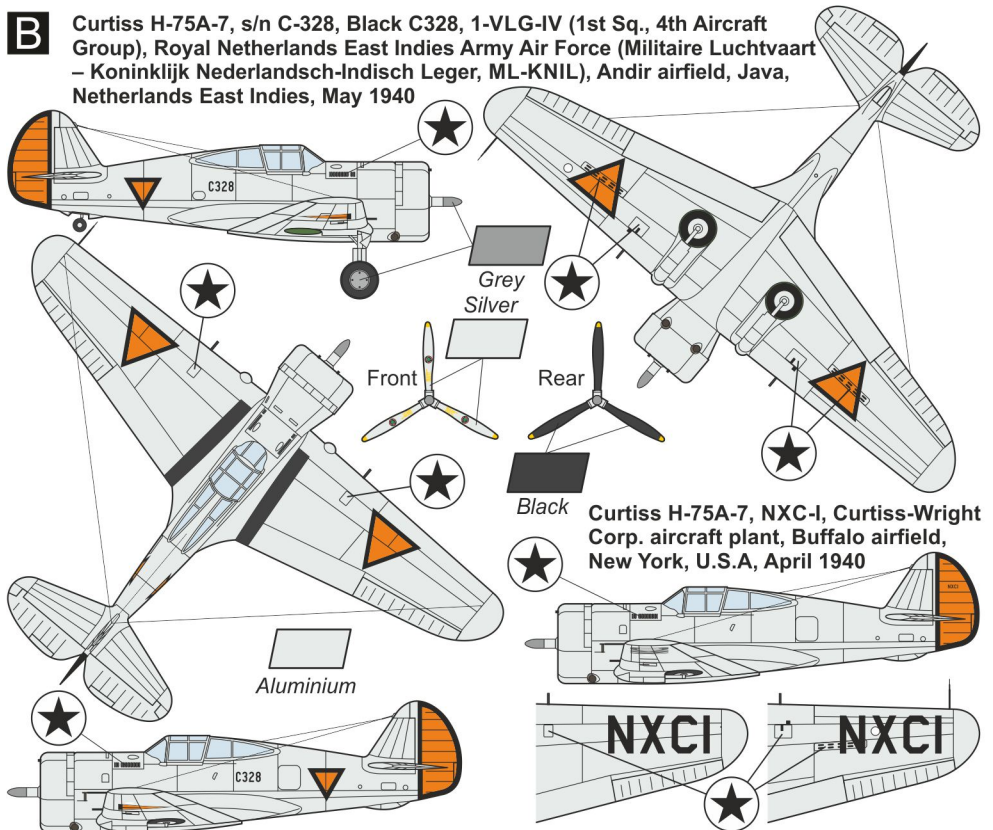

C Curtiss Mohawk Mk.IV, BJ441, Black OQ-J, No.5 Sq., Royal Air Force, Agartala airfield, Northeast India, October 1942

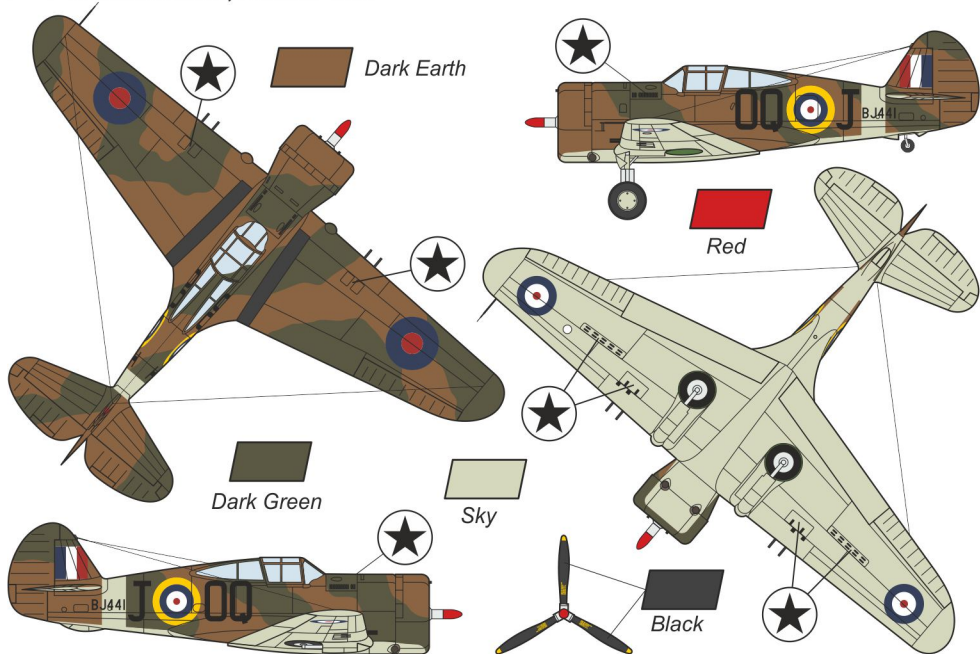

D Curtiss Mohawk Mk.IV (ex-Iranian H-75A-9), LA164, White 6, No.1 OTU (India), Royal Air Force, Risalpur airfield, North-West Frontier, India, June 1942

