

CURTISS H-75/MOHAWK MK.IV

ALLIED PILOTS



MKM144144
1/144 scale

parts not
to be used

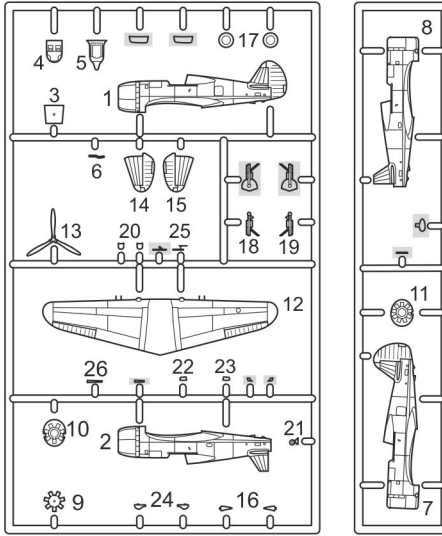

MARK I Ltd.
PO Box 10
Prague 10 - Strašnice
CZ-100 31
Czech Republic
mark1@cmail.cz
www.4pluspublications.com

clear parts

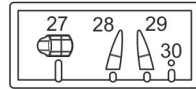

2x

2x

2x

plastic parts

2x Repeat this operation

Glue

Don't glue

Decal

Detach/cut

? Optional

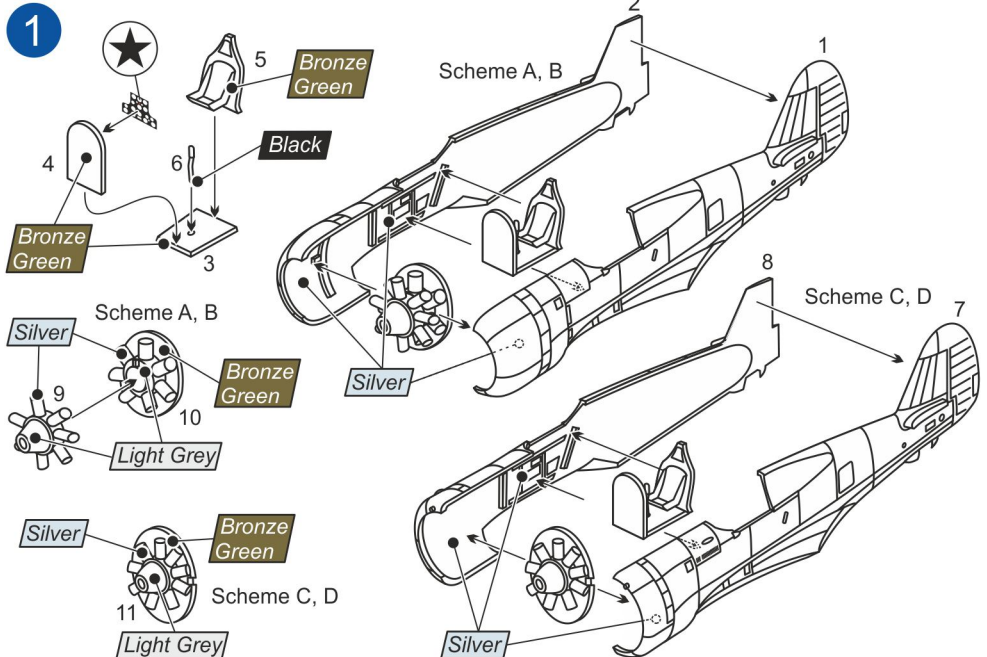

2

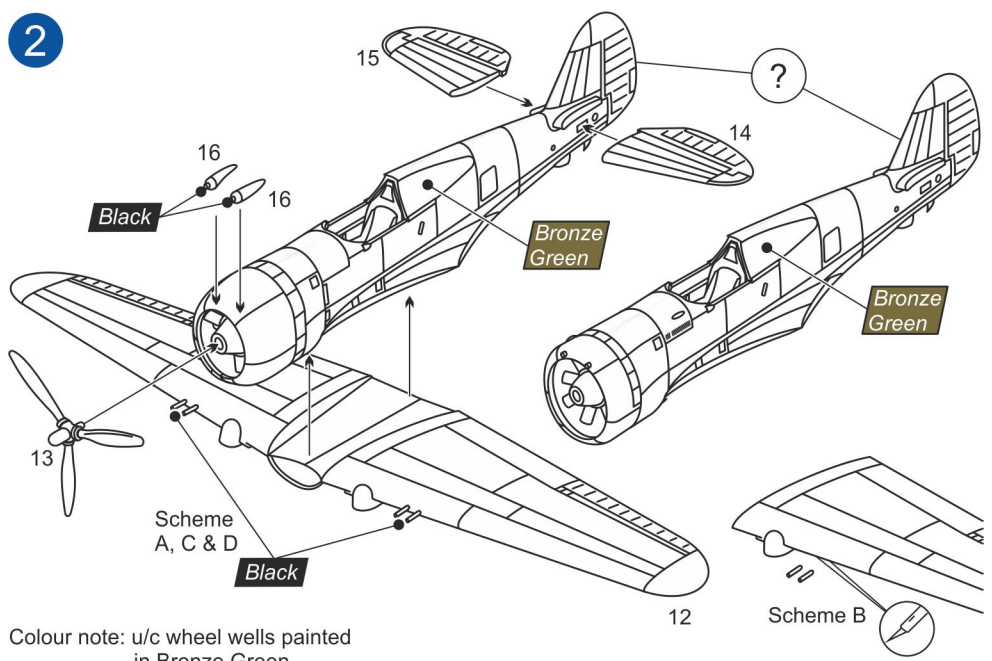

Colour note: u/c wheel wells painted in Bronze Green

3

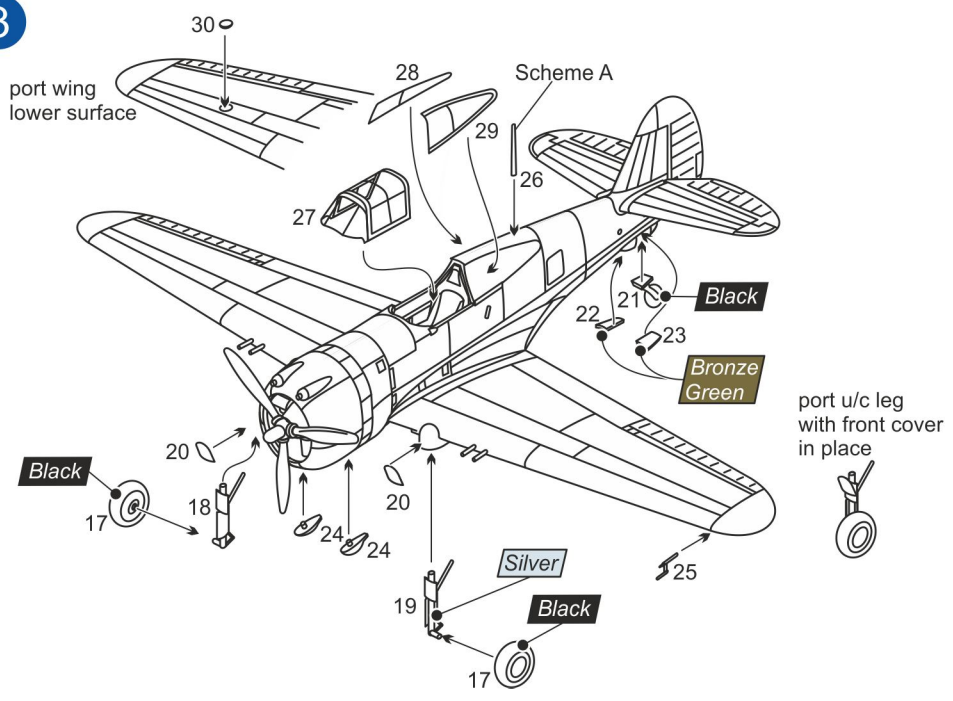

A Curtiss H-75A-3, No.230, White O, flown by Sgt. Marcel Milan, Free French Air Forces (Forces aériennes françaises libres, FAFL), Bangui airfield, Ubangi-Shari, French Equatorial Africa (Afrique-Equatoriale française, AEF), May 1941

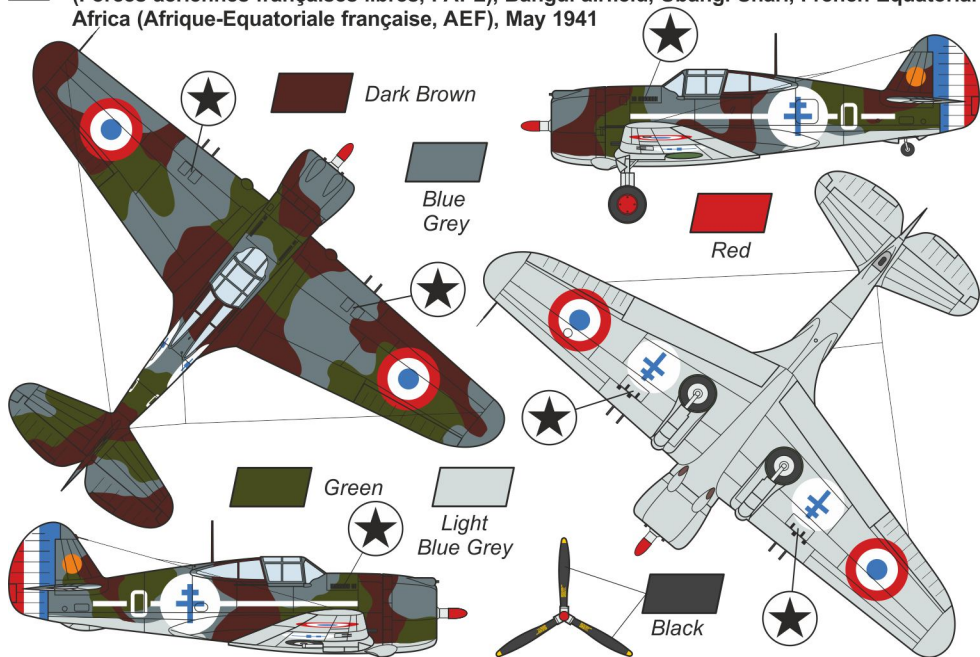

B Curtiss H-75A-3, No. 329, flown by S/Lt Lubomír Úlehla, Pilot's School, Free French Air Forces (Forces aériennes françaises libres, FAFL), Kasbah-Tadla airfield, Morocco, North Africa, 1944/45

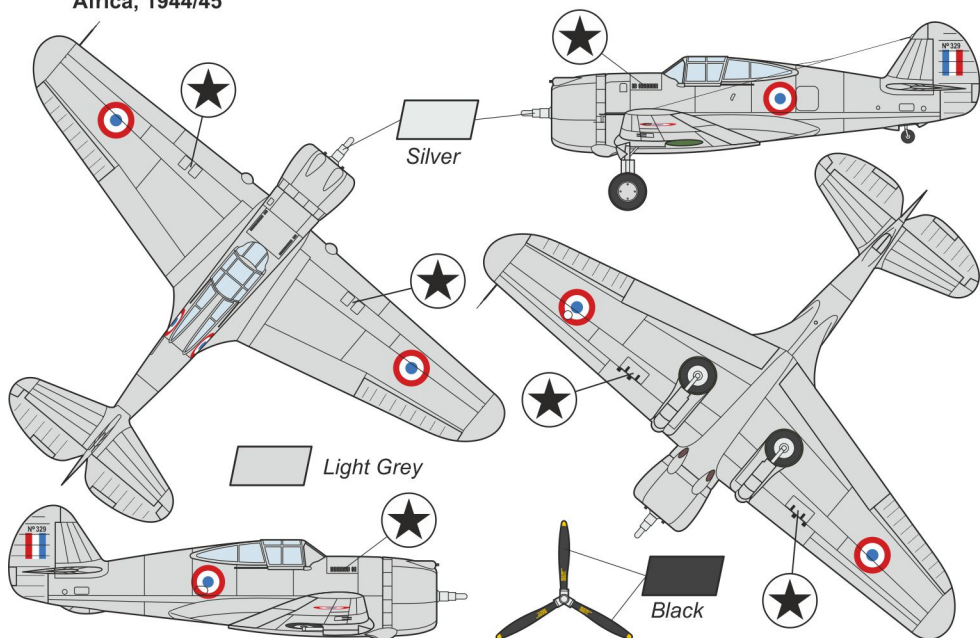

C Curtiss Mohawk Mk. IV, 2537 (ex-RAF Mohawk Mk. IV, BJ536), flown by the Flight Commander, No.3 'Fighting Wasp' Sq., South African Air Force, Alamata airfield, Ethiopia, Africa, summer 1941

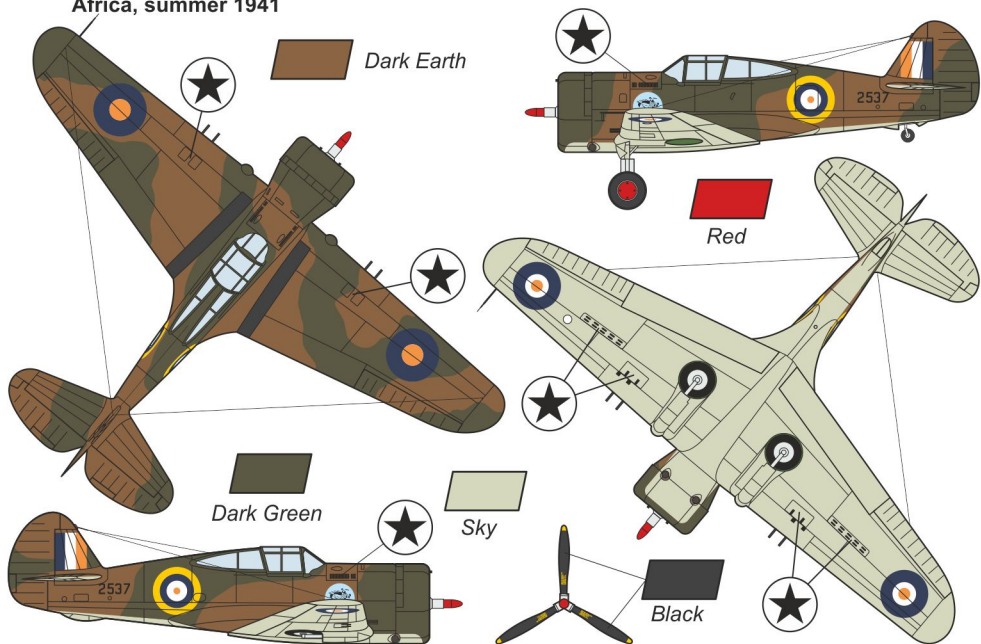

D Curtiss Mohawk Mk.IV, BB928, White Z, 'Cymru am Byth', flown by Sq Ldr Charles Jeffries (OC), No.155 Sq., Royal Air Force, Agartala airfield, Northeast India, January 1943

