

DHC-6-200/300 TWIN OTTER

WORLDWIDE MILITARY SERVICE



MKM144140
1/144 scale

parts not
to be used

MARK I Ltd.
PO Box 10
Prague 10 - Strašnice
CZ-100 31
Czech Republic
mark1@cmail.cz

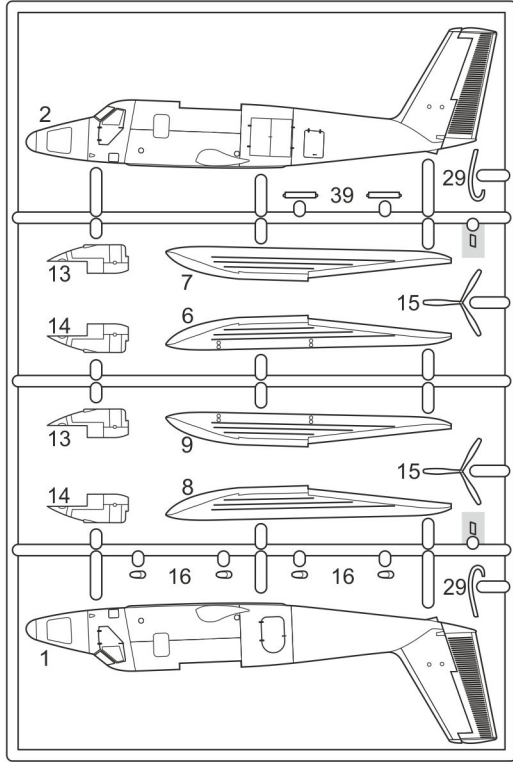

plastic parts

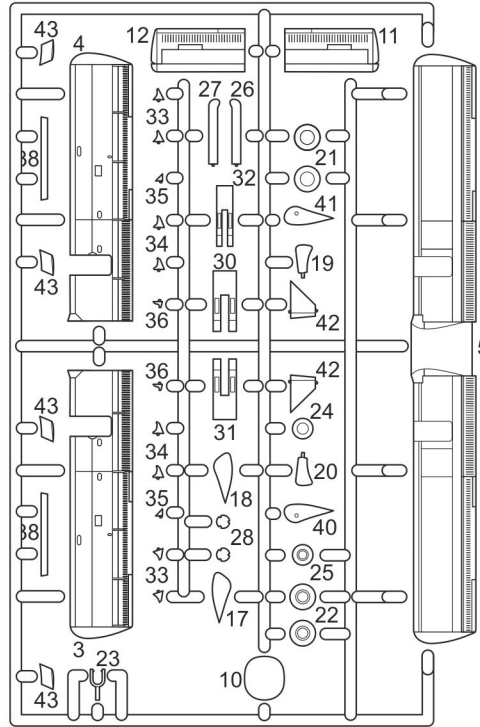

display base

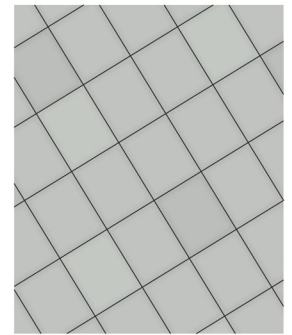

- Repeat this operation
- Glue
- Don't glue
- Decal
- Detach/cut
- Bend
- Drill
- Optional

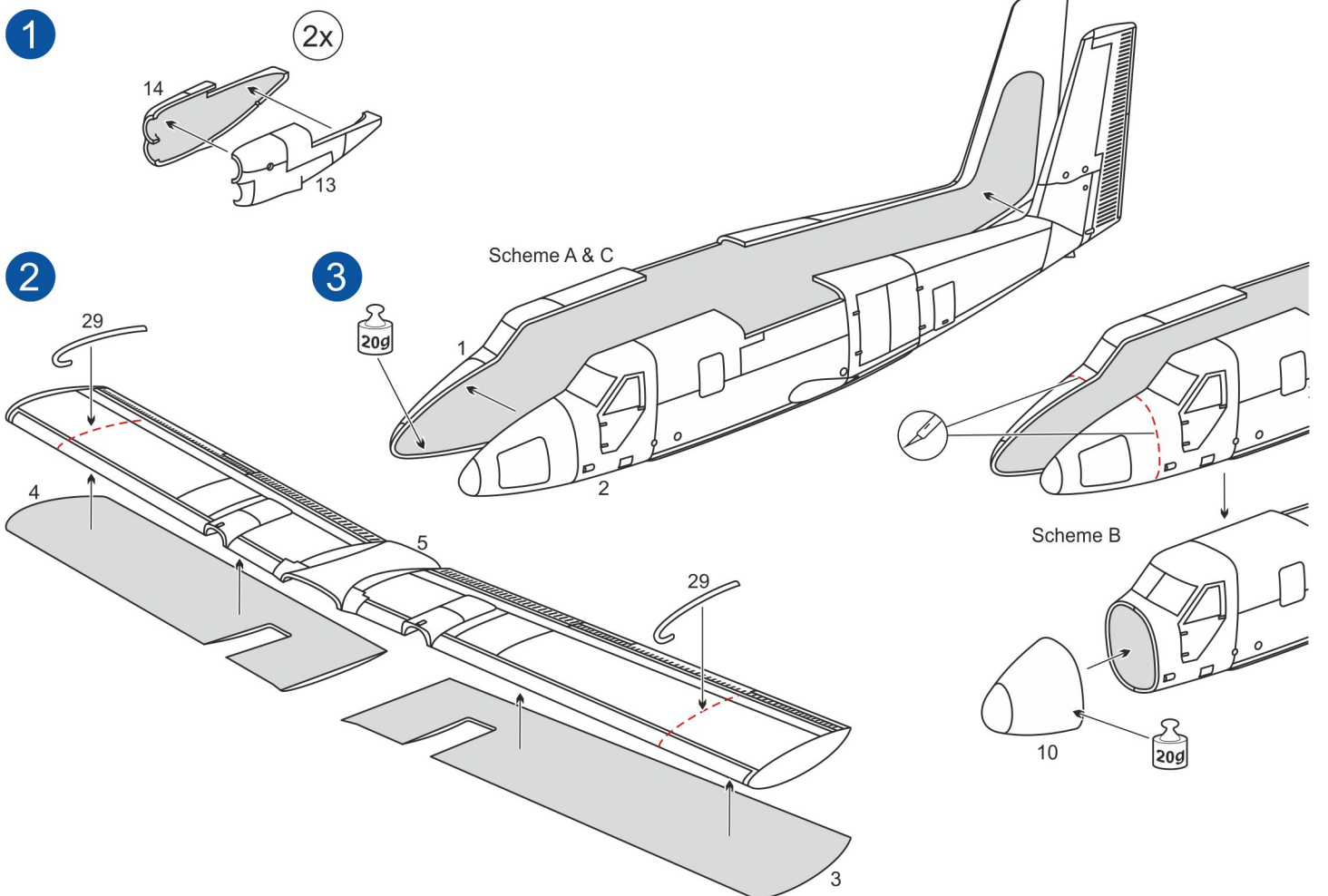

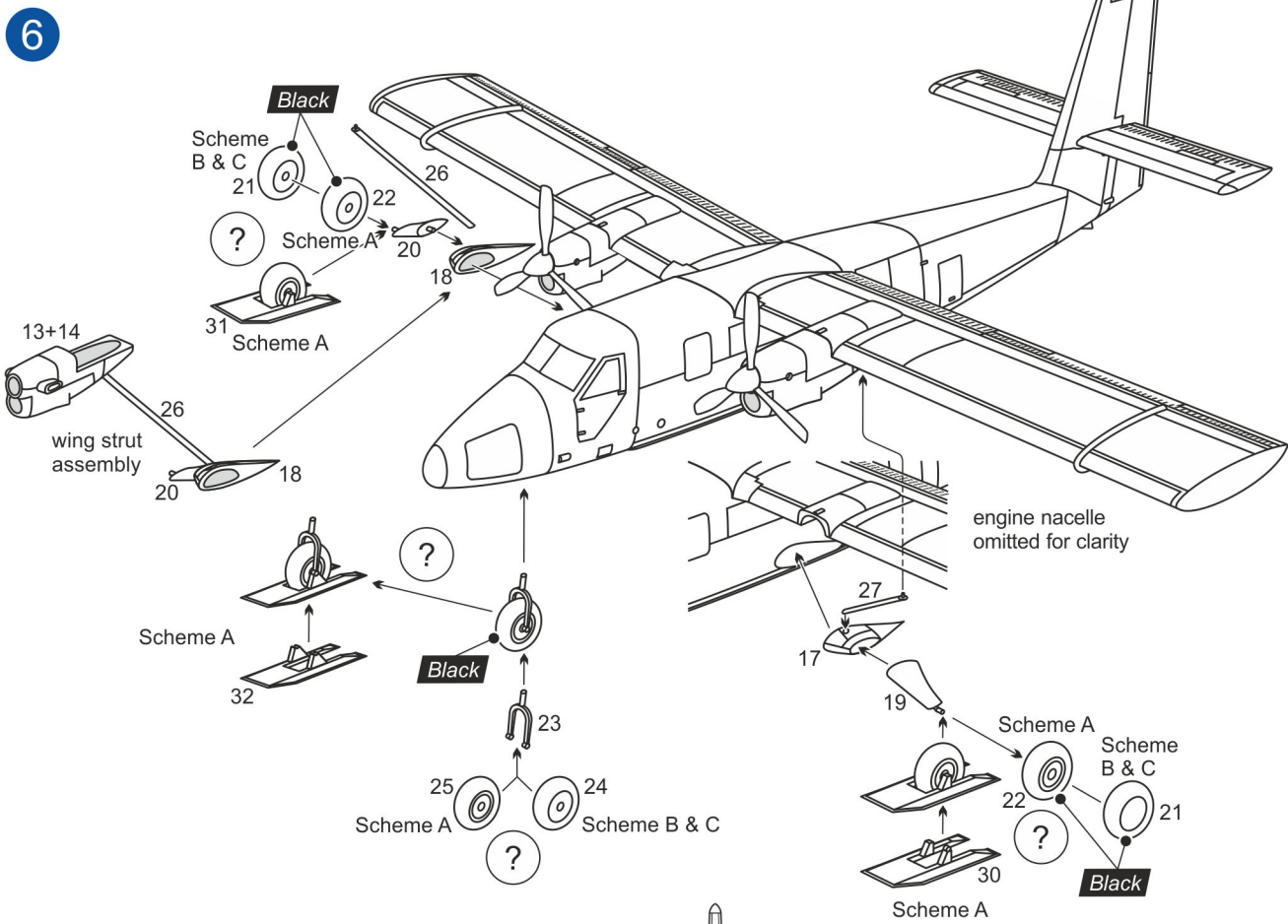
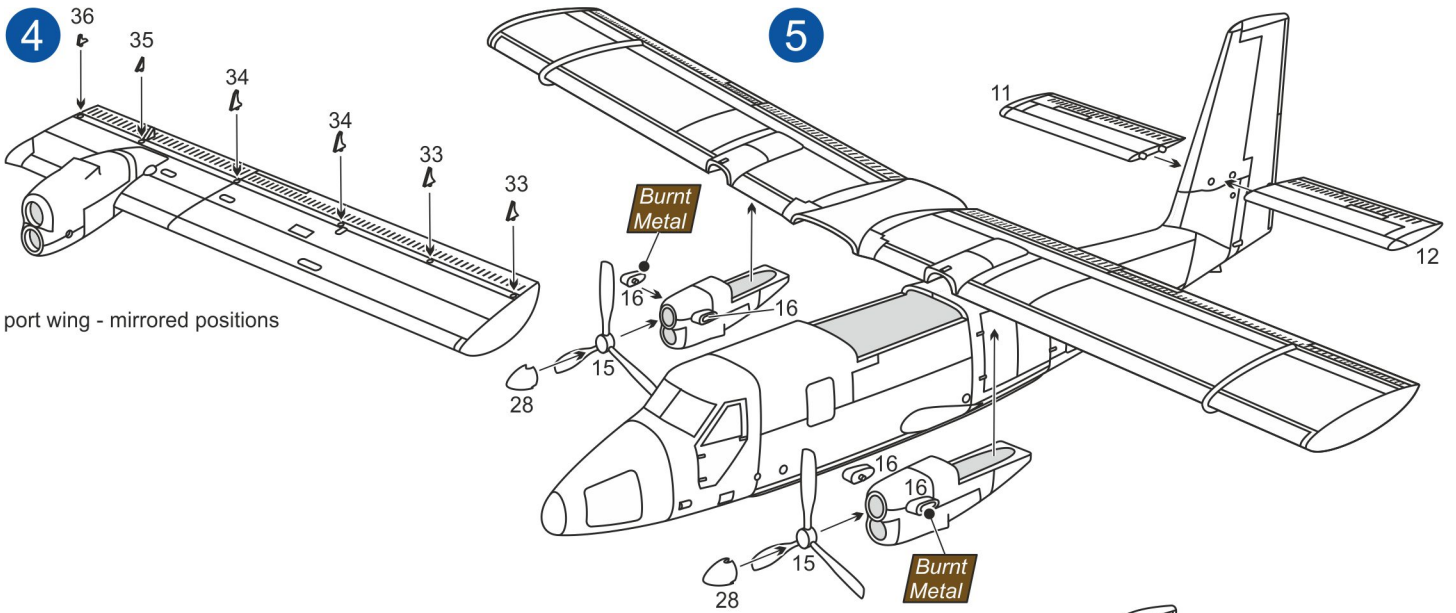

Front views

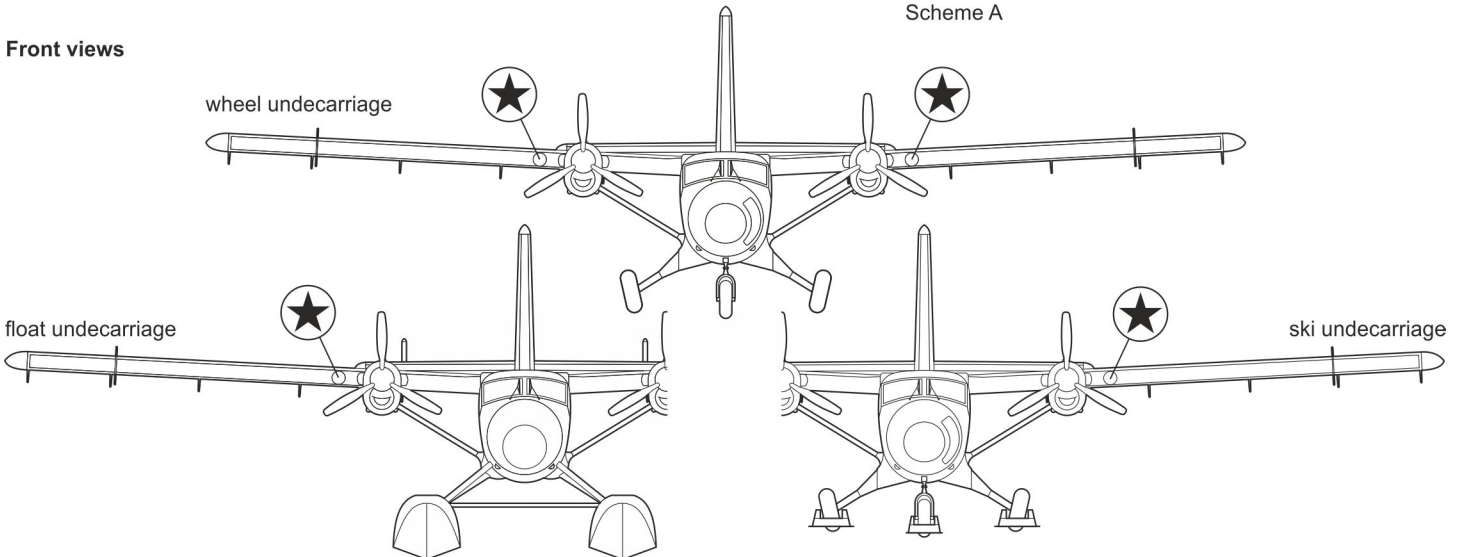

Scheme B

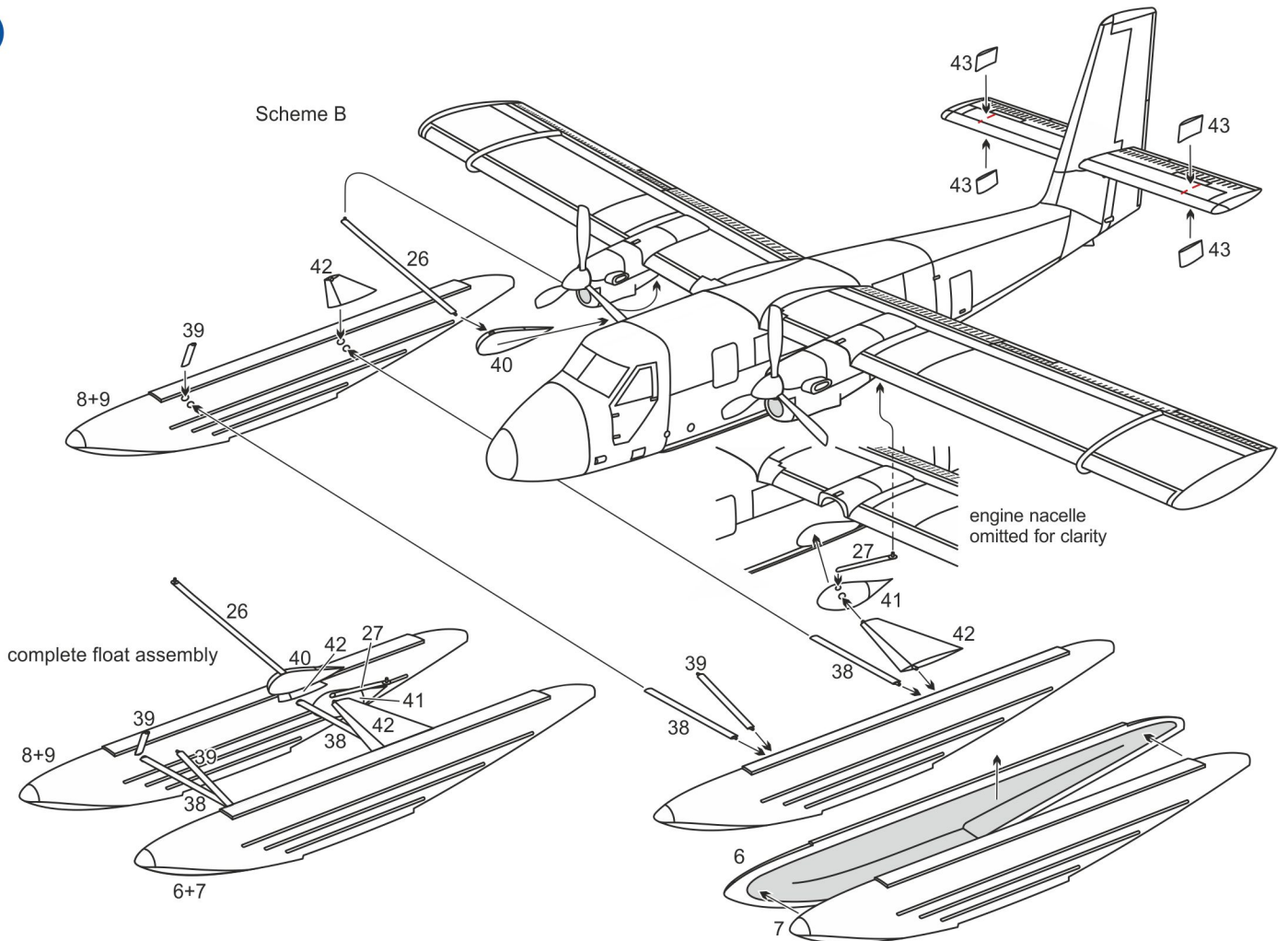

A de Havilland Canada DHC-6 (Series 200) Twin Otter, 73-184 (MSN 184), 184, No.719 Squadron (skvadron), Royal Norwegian Air Force (Luffforsvaret), Bodø Air Station, Norway, the 1990s

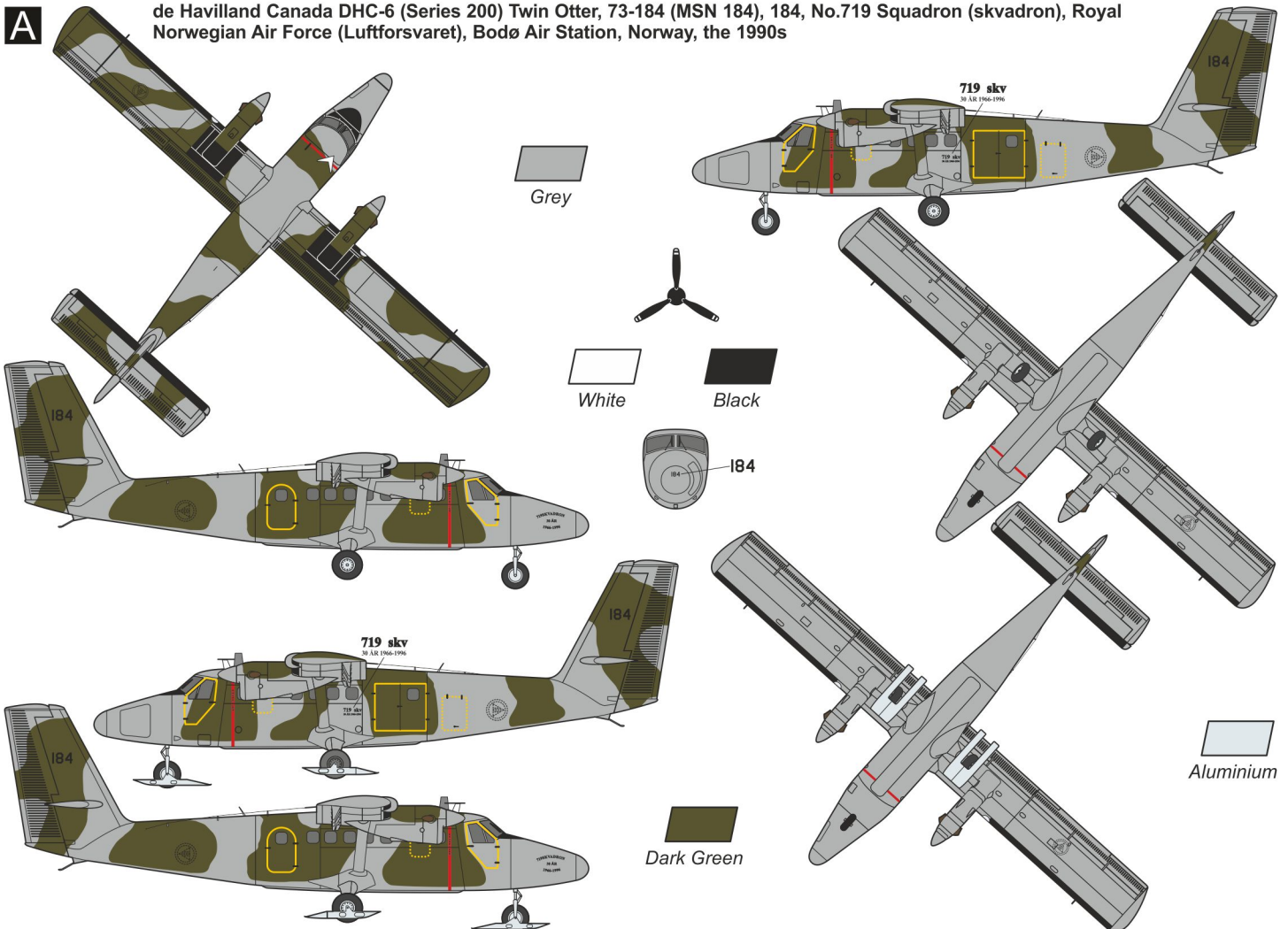

B

de Havilland Canada DHC-6 (Series 300) Twin Otter, FAP-313 (MSN 323), 313, Transport Squadron No.421 (Escuadron de Transporte), Air Group No.42 (Grupo Aéreo), Peruvian Air Force (Fuerza Aérea del Perú, FAP), Iquitos Air Base, Peru, 1971-73

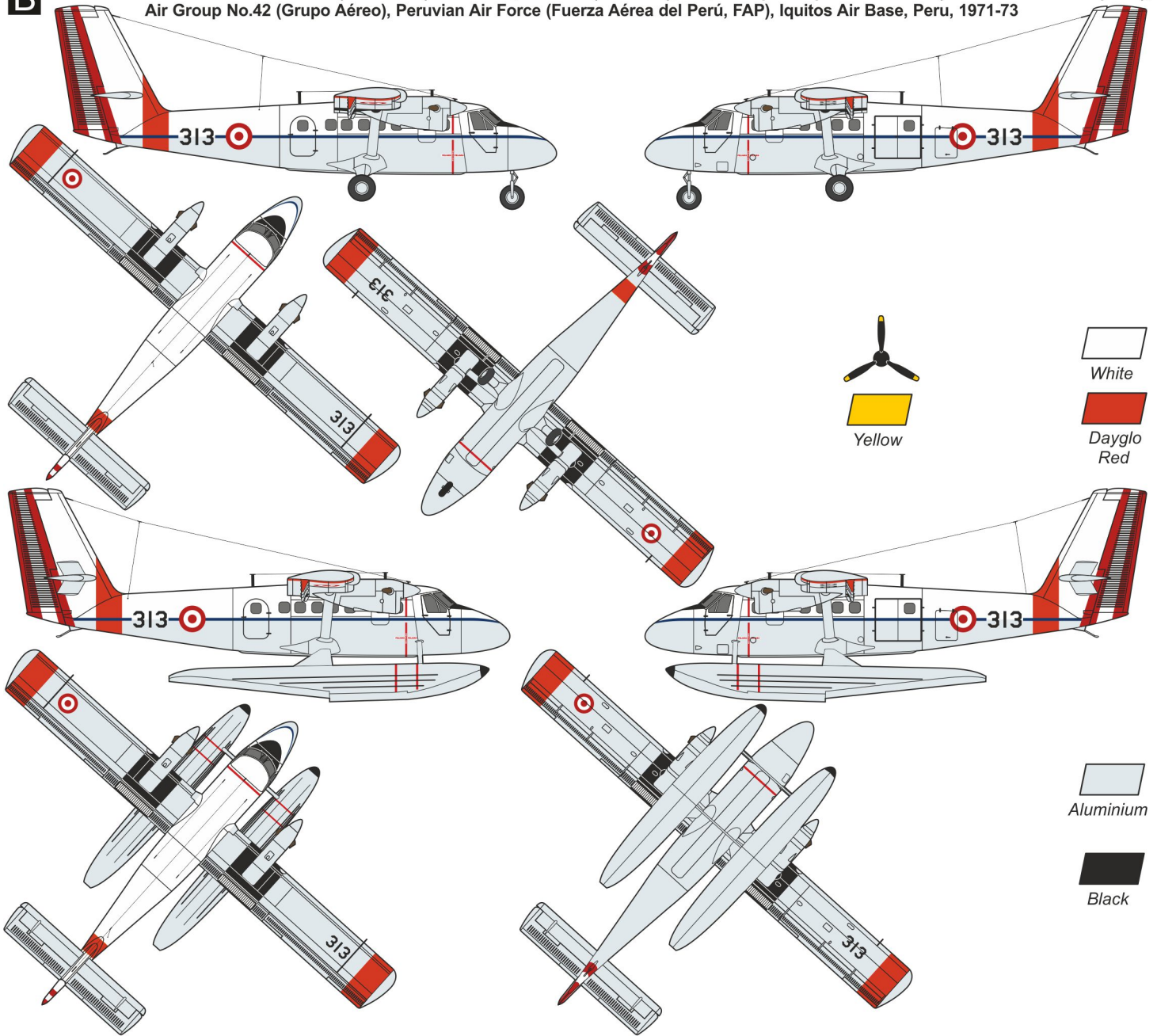
**C**

de Havilland Canada DHC-6 (Series 300) Twin Otter, FAF-730/F-RALF (MSN 730), 52-LF, Overseas Transport Squadron 52 (Escadron de Transport d'Outre-Mer 52, ETOM), French Air Force (Armée de l'Air), Air Base (BA) 186 Nouméa (La Tontouta), New Caledonia, early 1980s

