

LET L-13/TZ-13 BLANÍK

MILITARY SERVICE



MKM14495
1/144 scale

plastic parts

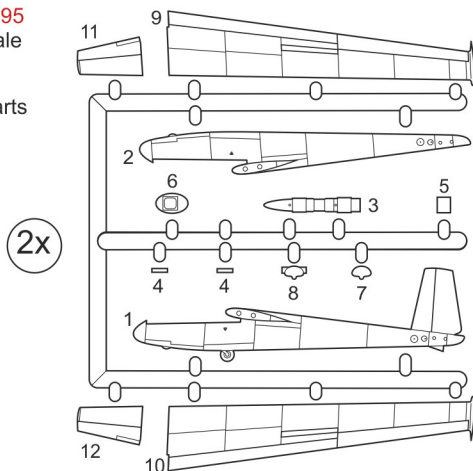

MARK I Ltd.
PO Box 10
Prague 10 - Strašnice
CZ-100 31
Czech Republic
mark1@cmail.cz
www.4pluspublications.com

clear part

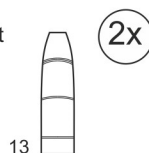

2x Repeat this operation

Glue

Don't glue

Decal

Detach/cut

Optional

Colour note: Interior colours could vary, the cockpit was basically Silver or Light Grey, with side-panel covering either in Grey, Light Brown, Light Blue, etc.

Cockpit floor colour also reflected the material used: Grey, Light Blue, Red or Brown. The seats had padded squabs (e.g., Brown) or cushions of various colours, while the backrests were made of canvas.

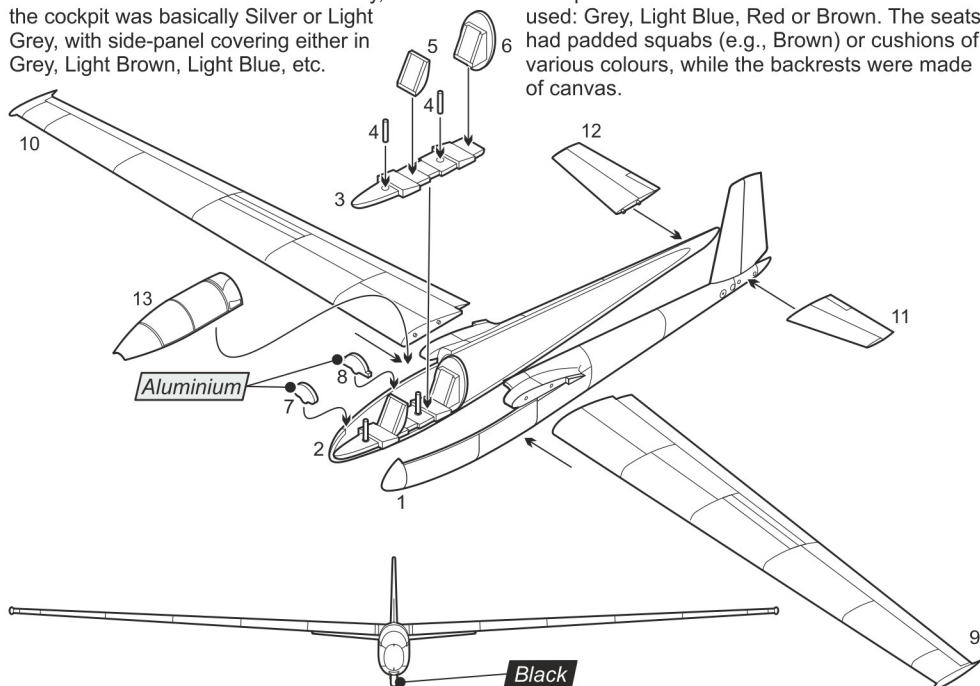

A

Let L-13 Blanik, Black R11 (c/n 026258), RAF Gliding and Soaring Association (RAFGSA), Aboyne, Aberdeenshire, Scotland, U.K., autumn 1980

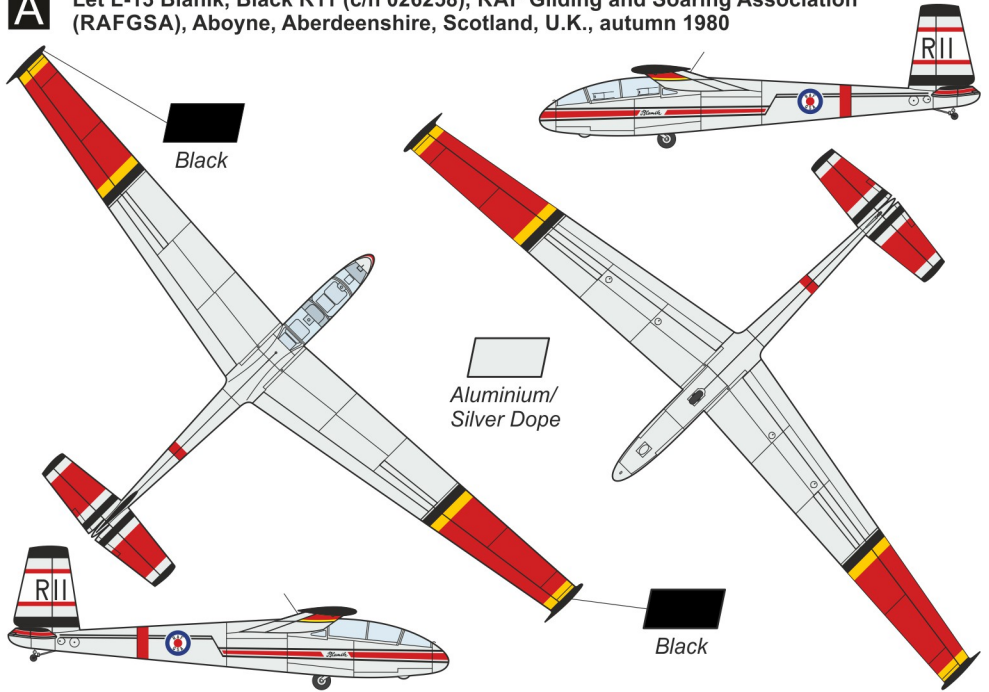
**B**

Let L-13 Blanik, Red 21, DOSAAF Volunteer Society for Co-operation with the Army, Aviation and Navy (Добровольное Общество Содействия Армии, Aviации и Флоту), Aeroclub Novosibirsk, the Soviet Union, early 1970s

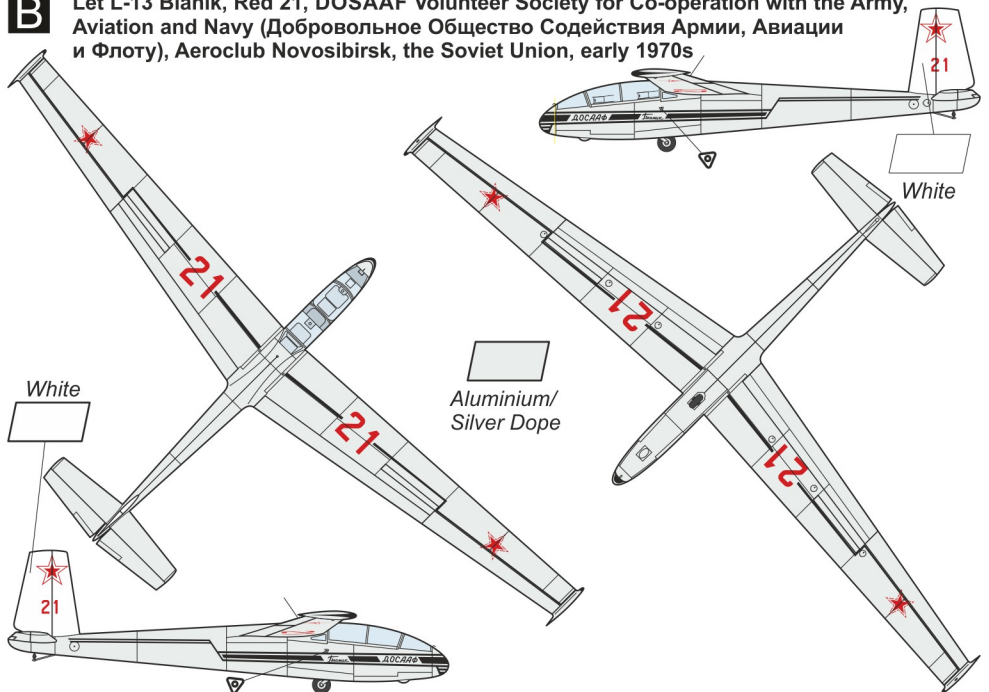

C

Let L-13 Blanik, No.23 outlined in Black, MM100047 (c/n 027009), CVV-14 Gliding Centre (Centro Volo a Vela), Italian Air Force (Aeronautica Militare), Frosinone Air Base, Italy, 1985

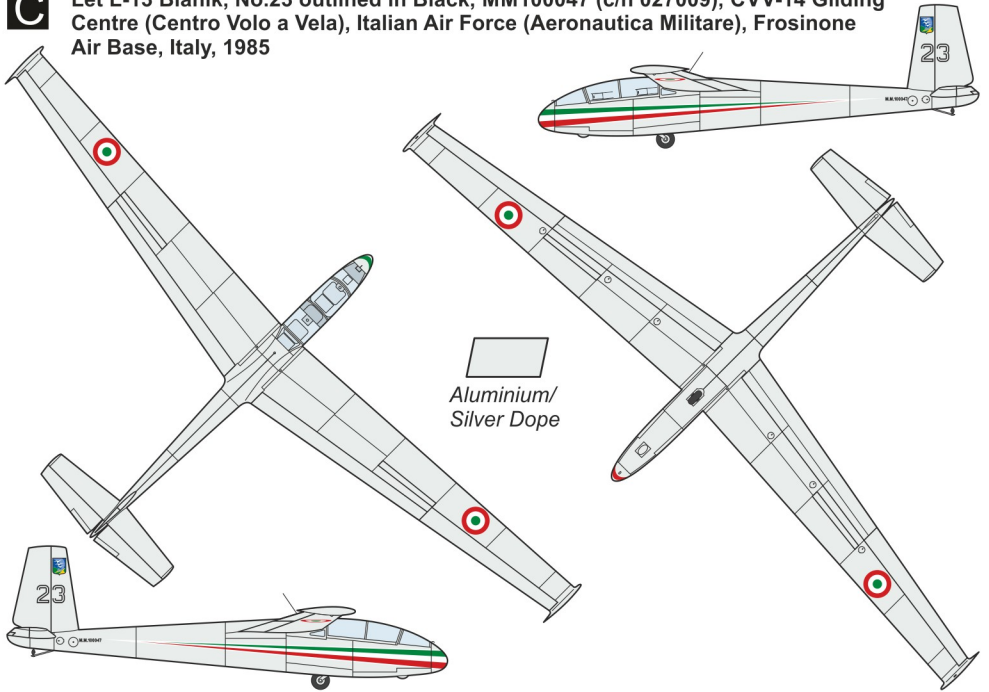
**D**

Let L-13 Blanik, Black 690 (c/n 0717), Military School of Aeronautics (Escuela Militar de Aeronáutica), Uruguayan Air Force (Fuerza Aérea Uruguaya, FAU), Gen. Artigas/Pando Air Base, Uruguay, 2014-15

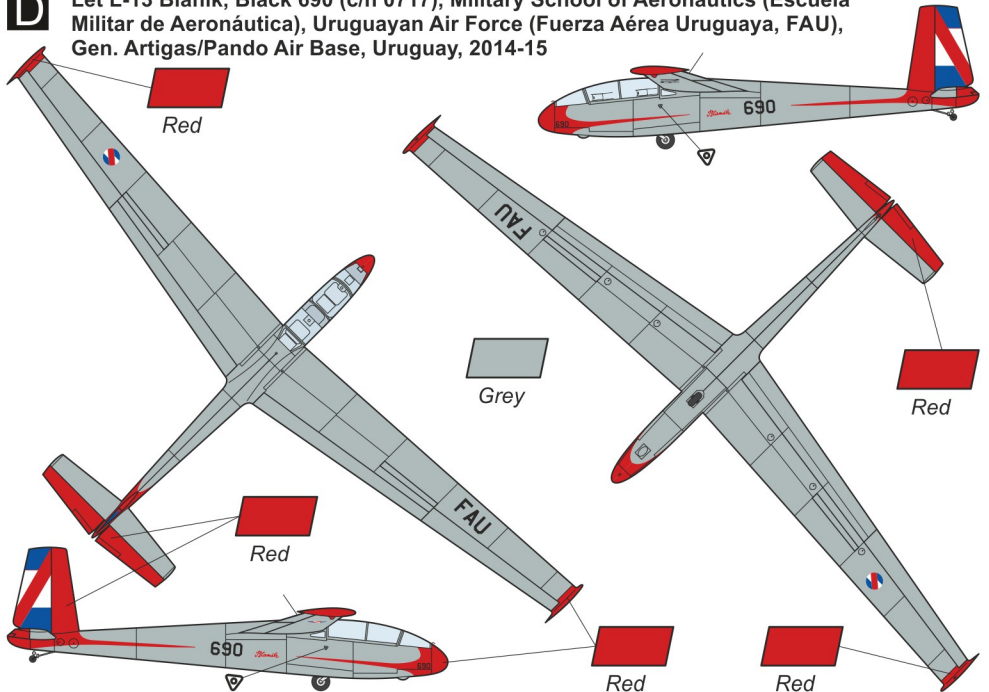

E

Let L-13 Blaník, Blue 08 (c/n 1420), Voluntary Border Defence Service (Krašto Apsaugos Savanriskos Pajėgos, KASP), Lithuanian Air Force, Silute Air Base, Lithuania, 1998

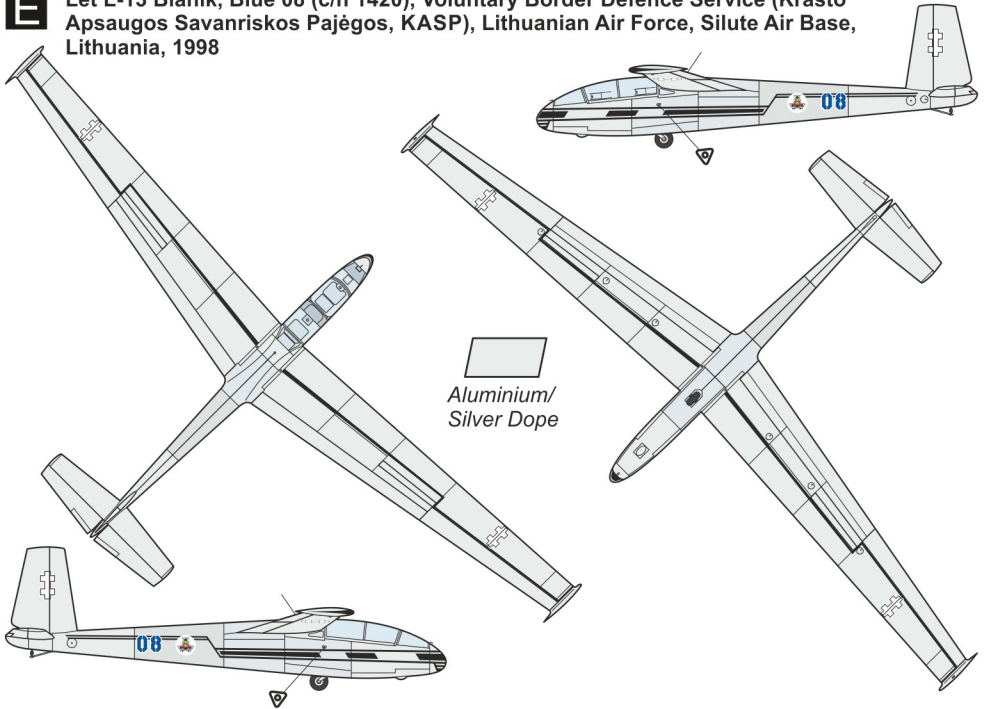
**F**

TZ-13 (Let L-13) Blaník, White 13 (8013), Clube de Voo à Vela (Sailing Flight Club), Air Force Academy (Academia da Força Aérea, AFA), Brazilian Air Force (Força Aérea Brasileira, FAB), Pirassununga Air Base, Brazil, the 1970-80s

